

Idrante a muro con tubazione flessibile da esterno/interno "LINEA ELECTA" DN 45 UNI EN 671-2
Fire hydrant with lay-flat hose for outdoor/indoor installation "ELECTA LINE" DN 45 UNI EN 671-2

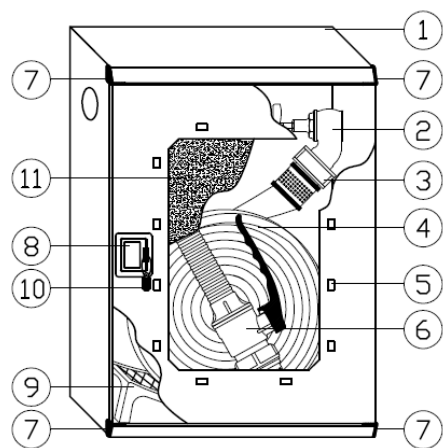

Vista inferiore-bottom view

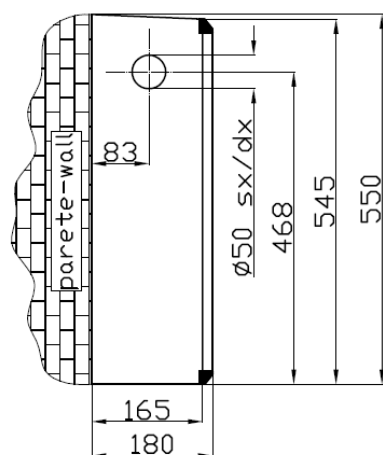
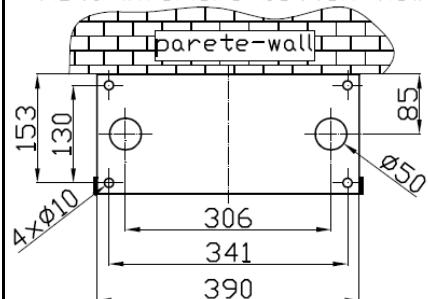

Art. 2/HX
 Acciaio INOX AISI 304 non verniciato
 Not painted Stainless Steel AISI 304



N°	Cod.	Descrizione - description	Materiale - material
1	0154X.036	Cassetta di contenimento (cod. indicato con portello) Fire cabinet (the code shown includes door)	Acciaio INOX AISI 304 non verniciato Not painted Stainless Steel AISI 304
2	0002.005	Rubinetto idrante DN 45x1"1/2 ISO 7 PN 16 Fire valve DN 45x1"1/2 ISO 7 PN 16	Ottone UNI - EN 1982 Brass UNI - EN 1982
3	0049.020	Raccordo DN 45 - UNI 804 forma A UNI 804 fire hose coupling DN 45 type A - Italian std	Ottone UNI - EN 1982 Brass UNI - EN 1982
4	ART/30A	Tubazione flessibile DN 45 UNI-EN 14540 mod. AB-PU Fire hose AB-PU DN 45 UNI - EN 14540	Calza in poliestere alta tenacità Jacket in high tenacity polyester
5	Portello - Door	Vedi cassetta - See fire cabinet
6	2145.074	Lancia frazionatrice a leva "STARJET" DN 45 Ø 12 "STARJET" branchpipe DN 45 Ø 12	Corpo e ugello in ottone/ tubo in polipropilene Body and tip in brass/ pipe in polypropylene
7	M60217	Copri spigoli - cerniere su lato destro Edges protection - Hinges on right side	Nylon
8	M60181	Maniglia - Handle	Acetalica - Acetal resin
9	0914.250	Sostegno per tubazione - Hose support	Polipropilene - Polypropylene
10	M65200	Sigillo - Seal	Plastica - Plastic
11	4004i.700	Lastra "FIRE GLASS" - Fire glass for cabinet	Plastica - Plastic

Tolleranze generali [mm] General tolerances [mm]	± 4
---	-----

Spessore min. lamierato Minimum plate tickness	6/10
---	------

Peso - Weight	
Con tubazione 15 m With 15 m hose length	10 kg
Con tubazione 20 m With 20 m hose length	11 kg
Con tubazione 25 m With 25 m hose length	12 kg
Con tubazione 30 m With 30 m hose length	13 kg

(Portata - Coefficiente K effettivo - Gittata) - (Flow rate - K factor - Throw distance):
 Lancia "STARJET" DN 45 con foro ugello 12 mm - "STARJET" branchpipe with outlet 12 mm

Posizione maniglia Handle Position	K	Portata riscontrata in prova - Real flow rate Q [l/min] @			Gittata - Throw distance @ 0,2 MPa [m]		
		0,2 MPa	0,4 MPa	0,6 MPa	Max	Eff.	
Getto pieno - Full jet	93,9	133	188	230	15,1	13,6	
Getto frazionato - Spray jet	75,1	106	150	184	6,2	5,6	
NOTE	K minimo previsto dalla norma e utilizzato nella DoP Min. K factor reported from standard and employed in DoP document					K=72	
Q [l/min] = K*v10p [MPa]	Angolo di erogazione con getto frazionato - Spray angle					45°	



BOCCIOLONE ANTINCENDIO S.p.A.

unipersonale
 Via Indren, 2 Z.I. Roccapietra - 13019 Varallo (VC) - ITALY
 TEL: 0163 - 568811 FAX: 0163 - 322022
 e-mail: info@bocciolone.com - www.bocciolone.com

SCHEDA TECNICA - DATA SHEET ST - 2HX - 01		
Descrizione - description	Art.	
Idrante a muro DN 45 "ELECTA". Lancia STARJET Ø 12- Fire hydrant DN 45 "ELECTA" STARJET branchpipe Ø 12.	2/HX	
Rev. 0	Data - Date: 06/06/2018	Pag. 1 di 2

Particolare asole di fissaggio – *Detail fixing holes*
 (vista posteriore cassetta) – *(cabinet rear view)*

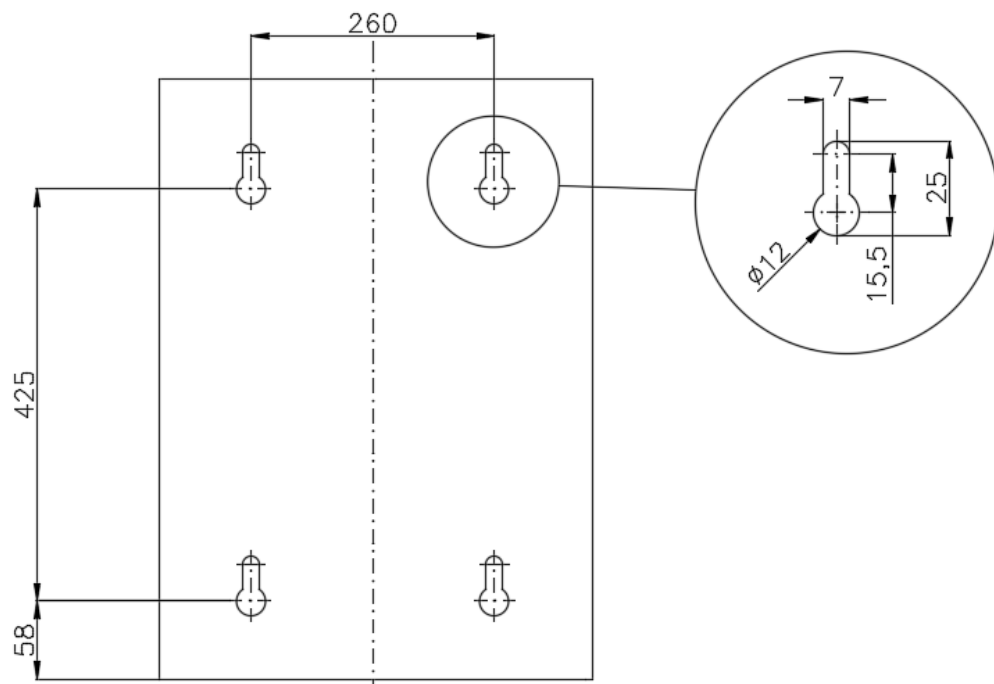

Particolare portello – *Door detail*
 (vista frontale cassetta) – *(cabinet front view)*

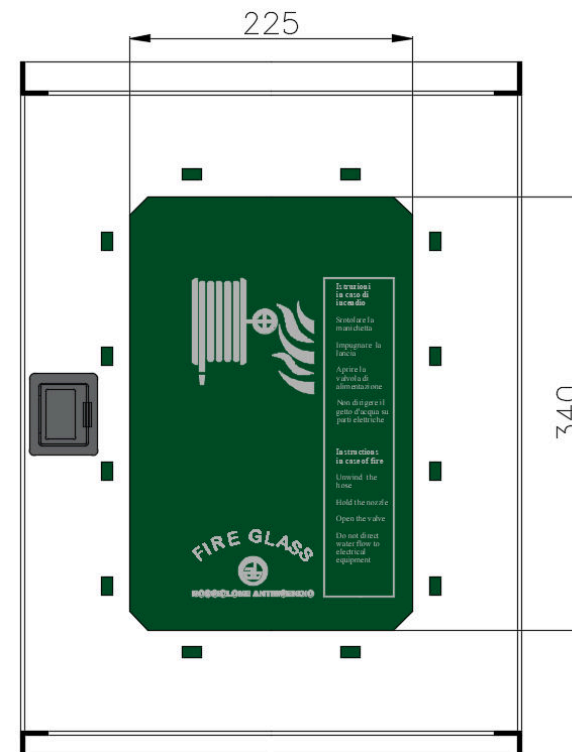

BOCCIOLONE ANTINCENDIO S.p.A.

unipersonale

Via Indren, 2 Z.I. Roccapietra – 13019 Varallo (VC) - ITALY

TEL: 0163 - 568811 FAX: 0163 - 322022

e-mail: info@bocciolone.com - www.bocciolone.com

SCHEDA TECNICA - DATA SHEET ST – 2HX – 01

Descrizione - description

Art.

Idrante a muro DN 45 "ELECTA". Lancia
 STARJET Ø 12- Fire hydrant DN 45 "ELECTA"
 STARJET branchpipe Ø 12.

2/HX

Rev. 0

Data – Date: 06/06/2018

Pag. 2 di 2